

# RFIK Series

## Mechanical Hydraulic Tester

The RFIK mechanical hydraulic tester provides the ideal solution for servicing and commissioning hydraulic circuits on agricultural and other mobile machinery. The kit comprises of a direct acting flow indicator with built in thermometer, a loading valve and a pressure gauge all built into a strong steel case with a removable lid.

The unit is self contained and requires no electrical power. The dials are clear and easy to read. Installation is extremely simple and the test kit can be connected into either the pressure or return lines. The loading valve and pressure gauge allow a progressive build up of system pressure in complete safety.

The test kit provides the service engineer with quick, accurate and simple performance testing of pumps, motors, valves, steering systems, cylinders and complete hydraulic circuits.

### Specifications

<b>Maximum Rated Pressure:</b>	Up to 420 bar, 6090 psi
<b>Maximum Flow:</b>	Up to 270 L/min, 70 US gpm
<b>Ambient Temperature Range:</b>	-10 to 50°C, 14 to 122°F
<b>Fluid Temperature Range:</b>	20 to 80°C, 68 to 176°F
<b>Compatible Fluids:</b>	Mineral oils, Other fluids consult sales office
<b>Accuracy:</b>	<b>Flow:</b> ± 4% FS
	<b>Pressure:</b> ± 1.6% FS
	<b>Temperature:</b> ± 2.5 °C, ± 5 °F
<b>Porting:</b>	BSPP, UN
<b>Material:</b>	<b>Body Materials:</b> Aluminium
	<b>Internal Materials:</b> Stainless Steel, Brass
	<b>Seals:</b> NBR
<b>Weight:</b>	6.6 kg, 14.6 lb

### ISO Symbol:

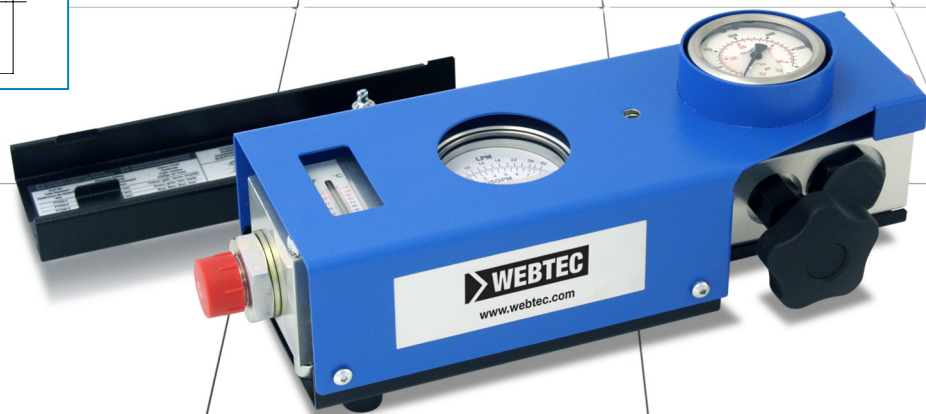
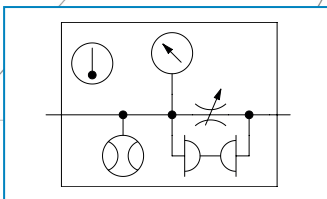

### Make it **BLUE**<sup>®</sup> Features

- Up to 270 L/min, 70 US gpm
- Built-in thermometer
- Allows reverse flow
- No batteries required
- Large clear easy to read dials
- Smooth pressure control up to 420 bar, 6000 psi
- Safe to use, with 'INTERPASS'<sup>™</sup> internal safety protection system. Protects system and operator against accidental over-pressure in both flow directions

## Sales Order Code

Please contact our technical sales team to discuss any special order requirements.

MODEL NUMBER	INLET FITTING	OUTLET FITTING	CALIBRATED FLOW RANGE	
			L/MIN	US GPM
RFIK030-B-6	3/4" BSPP	3/4" BSPP	2 - 30	0.5 - 8
RFIK060-B-6	3/4" BSPP	3/4" BSPP	5 - 60	1 - 16
RFIK120-B-6	1" BSPP	1" BSPP	10 - 120	4 - 32
RFIK200-B-6	1" BSPP	1" BSPP	10 - 200	4 - 54
RFIK270-B-6	1" BSPP	1" BSPP	20 - 270	5 - 70
RFIK030-S-6	1-1/16" - 12UN JIC MALE	1-1/16" - 12UN JIC MALE	2 - 30	0.5 - 8
RFIK060-S-6	1-1/16" - 12UN JIC MALE	1-1/16" - 12UN JIC MALE	5 - 60	1 - 16
RFIK120-S-6	1-5/16" - 12UN JIC MALE	1-5/16" - 12UN JIC MALE	10 - 120	4 - 32
RFIK200-S-6	1-5/16" - 12UN JIC MALE	1-5/16" - 12UN JIC MALE	10 - 200	4 - 54
RFIK270-S-6	1-5/16" - 12UN JIC MALE	1-5/16" - 12UN JIC MALE	20 - 270	5 - 70

*To order a RFIK please quote the model number from the table above*

## Accessories:

A range of burst discs are available - please consult the sales office.

Note: Calibration certificates are available on request - this is a chargeable option. Other calibration on request - please consult sales office.

## Fluid Temperature Conditions

For temperature ranges 20 to 80 °C (68 - 176 °F) continuous use. Intermittently (< 10 minutes) of up to 110 °C (230 °F).

## Reverse Flow

The tester will allow reverse flow but will not measure the reverse flow, i.e. the flow needle will indicate zero.

## Safety Discs

Protection against over pressure is provided by two internal safety discs which relieve at 420 bar (6000 psi) without external spillage. The safety discs are housed in a cartridge and are easily replaceable. Each unit is supplied with four spare discs.

## Operation

There are two main elements to the RFIK - the reverse flow indicator (RFI) and the load valve. The flow indicator block houses a metering piston which moves against a calibrated spring. The piston is magnetically coupled to a rotary pointer to provide a direct reading of flow on the dial, flow scale is displayed in both L/min and US gpm. The thermometer also mounted in the flow block near the fluid flow. Both flow and temperature scales are shielded behind impact resistant windows.

The load valve is connected directly to the flow block and a 420 bar (6000 psi) pressure gauge is mounted in the inlet section of the loading valve. The valve is easy to operate and, combined with the pressure gauge, allows sensitive and progressive control of system pressure throughout the working range.

**RFIK030 / RFIK060**

**Pressure Drop - load valve fully open - forward flow**  
All test completed using ISO32 mineral oil at 40 °C (32cSt)

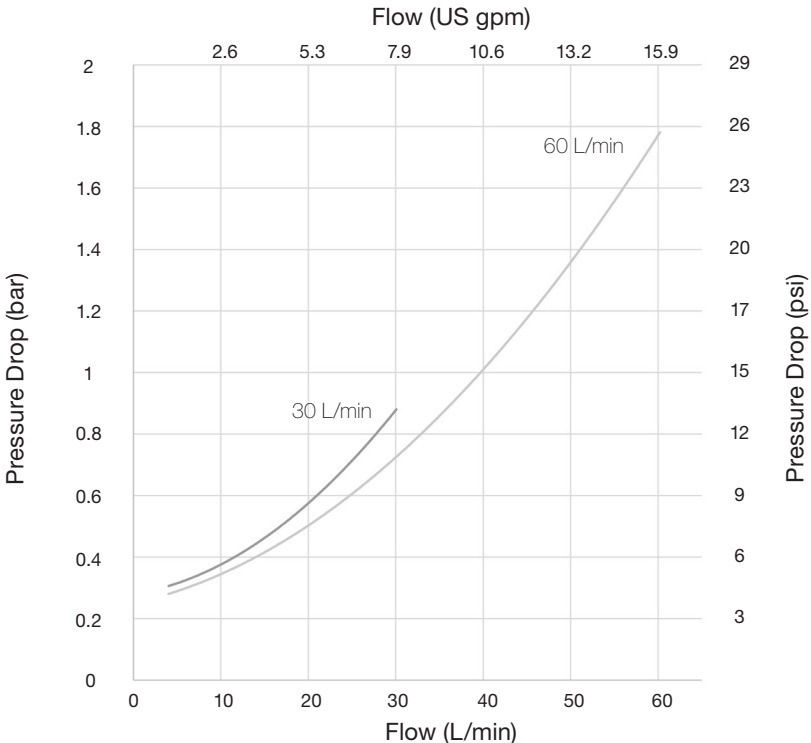

**RFIK120 / RFIK200 / RFIK270**

**Pressure Drop - load valve fully open - forward flow**  
All test completed using ISO32 mineral oil at 40 °C (32cSt)

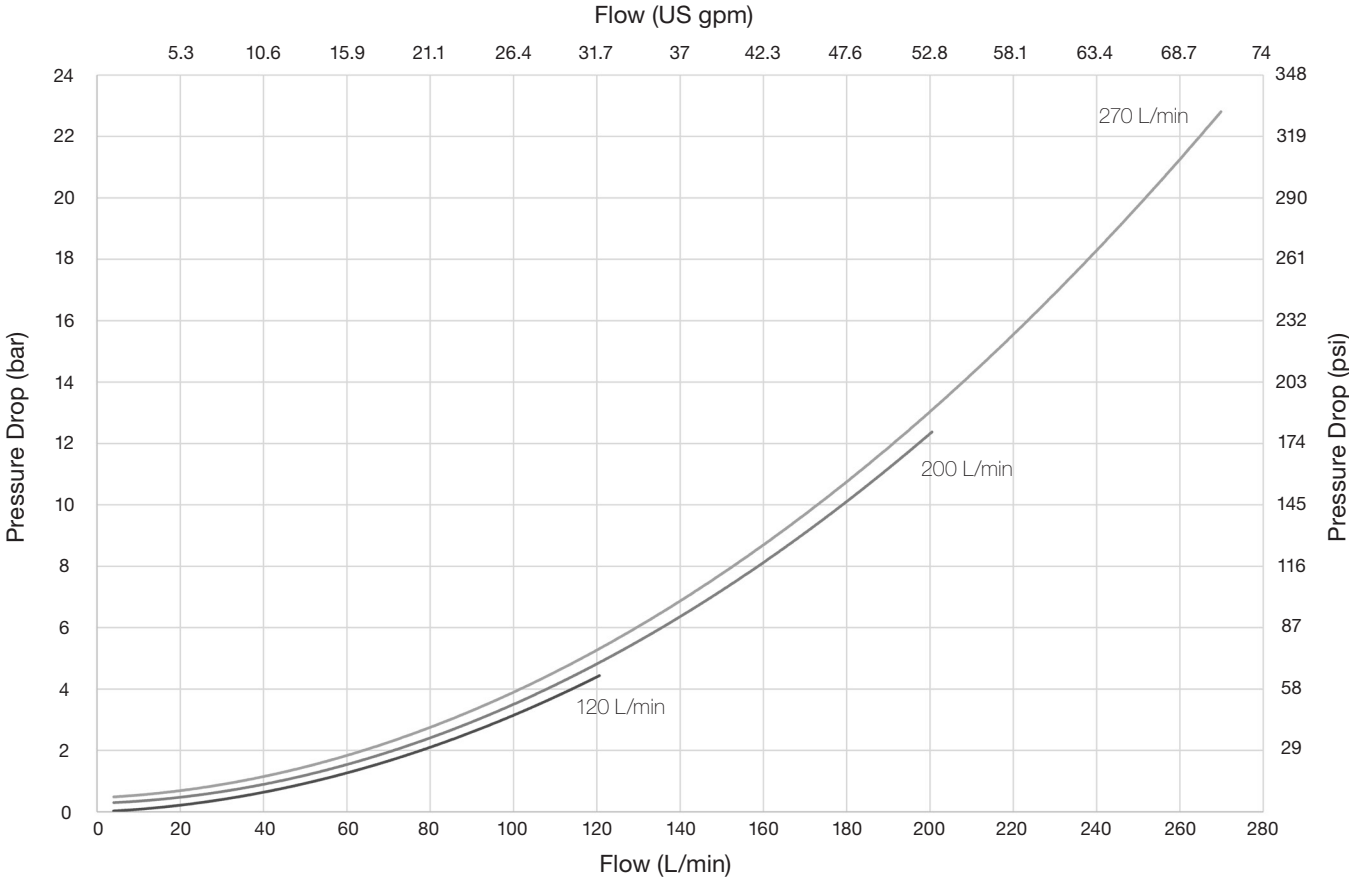

## Installation Details

Dimensions in mm [Inches]

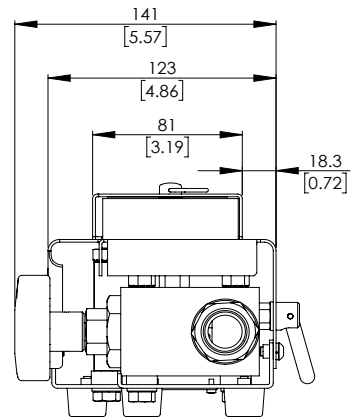
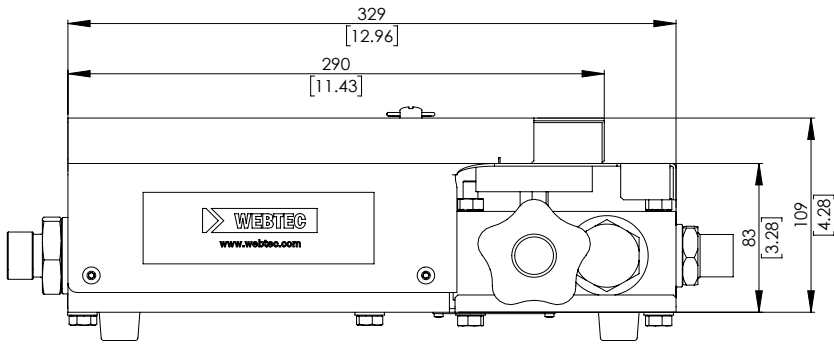
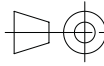

## Overall System Test

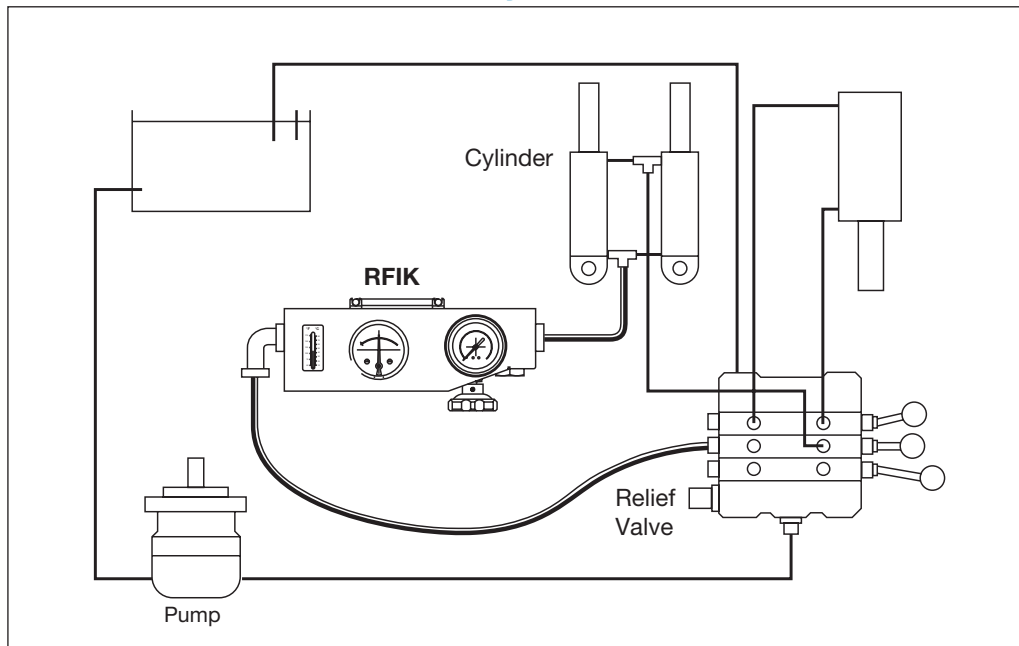

## Installation

It is recommended to connect with flexible hoses of at least 500mm (1.5') in length. This unit is not designed for permanent installation.

Your supplier:



Aroflex AG | CH-8560 Märstetten  
[www.aroflex.ch](http://www.aroflex.ch) | [info@aroflex.ch](mailto:info@aroflex.ch)

Webtec reserve the right to make improvements and changes to the specification without notice